



## Modular Rheometer Platform for Individual Demands

**Thermo Scientific HAAKE MARS III**

**FACTOR 01**  
**FUTURE-ORIENTED**

*“What we offer most likely exceeds your present requirements, but will support your future applications without exception.”*



As the world leader in serving science, with over 350,000 customers, we also stand for powerful rheometers.

In the further development of the Thermo Scientific HAAKE MARS rheometer platform we have focused on the following factors:

- Future orientation
- Accuracy
- Ease of use
- Modularity
- Application solutions

More than ever, the name “MARS” reflects the philosophy of the product: Modular Advanced Rheometer System.

As one of the most modular rheometers in its class, the HAAKE MARS is designed to meet the most demanding requirements in research and development while remaining open to technical customizations and future developments.

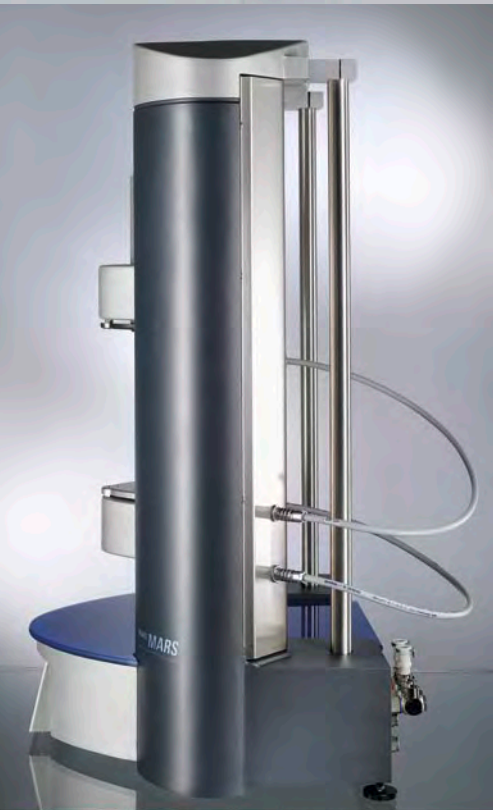

### **Expandable for the Future**

**HAAKE MARS – rheometer platform for individual demands – today and tomorrow:**

- Wide range of accessories
  - Temperature modules
  - Application-focused measuring cells
  - Measuring geometries
- Compatible with accessories for the previous model and the Thermo Scientific HAAKE RheoStress series
- Adaptable to evolving testing requirements with new accessories
- Hardware and software upgrades for existing HAAKE MARS users to benefit from future technological innovations

## FACTOR 02 ACCURACY

Measuring head with upper mount lifts to accommodate sample

Fixed lower mount attaches temperature control units and the RheoScope module securely

Ergonomic control panel with 5-button keypad plus menu button for status/error display

Integrated control electronics for exchangeable temperature modules including control valves for optimal temperature control

Additional access from below for individual testing requirements

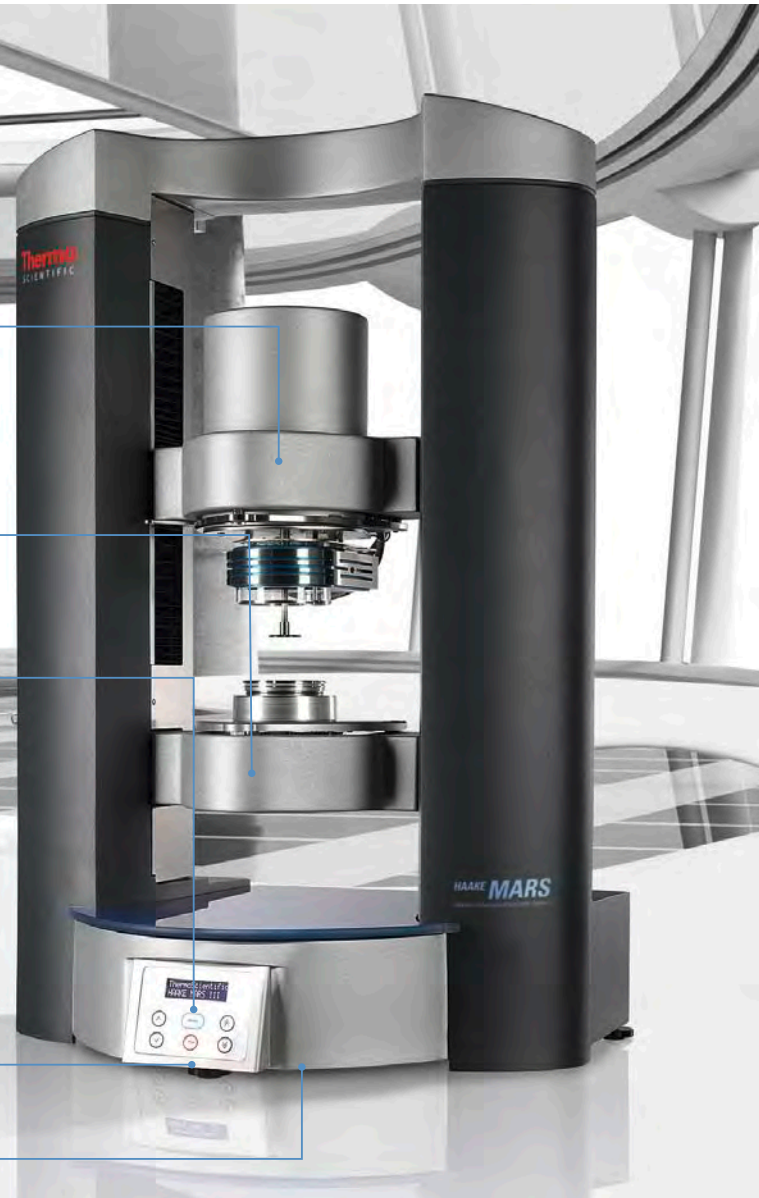

## H-shaped Frame

A one-piece, aluminum-cast H-shaped frame offers unmatched stability and optimizes force distribution.

Mounting rods (optional) for temperature-controlled test chamber and other additional modules for combined measurement methods

# MARS FACTOR 02 ACCURACY

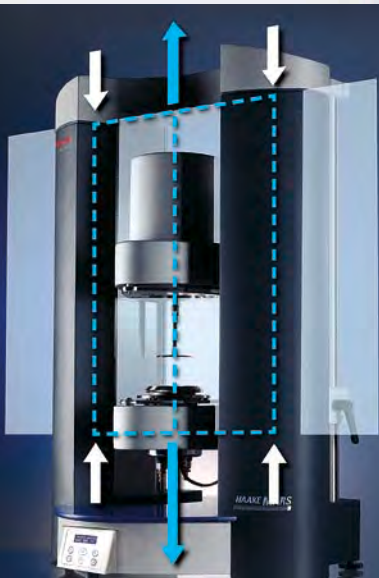

## Optimal force distribution

The active forces from the sample and the reactive forces in the frame act in the same plane in the HAAKE MARS "H-shaped" frame. This effectively prevents the gap from widening as a result of high normal forces contrary to a standard "C-shaped" frame.

## Mechanical precision production of all components

All components, such as the temperature modules and their guides are designed for fast, simple installation – without additional adjustment. The optimal, automatic positioning is based on plane parallelism and centricity.

**FACTOR 02  
ACCURACY**



**HAAKE MARS III measuring  
head with optimized,  
patented components  
Detail view**

4th generation patented diffusion  
air bearing at extremely low moment  
of inertia (nNm) to measure at a very  
low inertia (nNm)

Drag-cup motor with  
an extremely low inertia

Optical encoder for high  
angular resolution

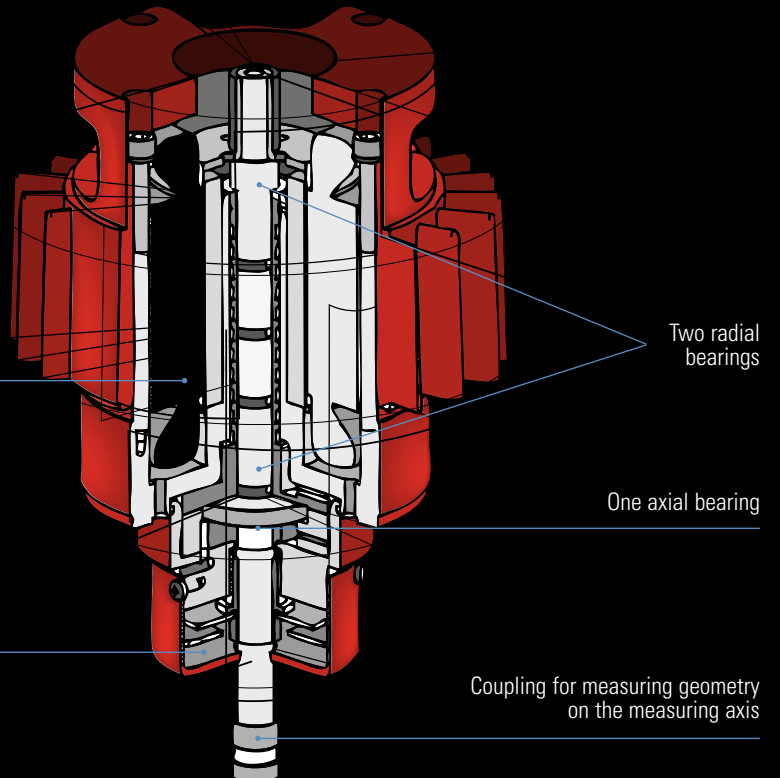

Coupling for measuring geometry  
on the measuring axis



## Motor

The HAAKE MARS drag cup features the lowest inertia of  $10 \mu\text{Nms}^2$  and due to that has fast response characteristics. The integrated memory chip contains all relevant calibration data and therefore allows a quick exchange of the measuring head without time-consuming calibration.

## Air bearing

The highly precise and patented 4th generation air bearing\* in the HAAKE MARS is the result of more than 30 years of experience and development. The HAAKE MARS air bearing system is based on the interaction of three individual air bearings:

- One axial air bearing, supporting the motor shaft in the vertical direction, and is responsible for excellent axial stiffness.

- Two separate, widely spaced radial air bearings support the motor shaft in the radial direction.

## Optical encoder

The HAAKE MARS optical encoder is mounted to the bottom of the measuring head to minimize the influence of the inevitable compliance of the motor shaft.

The optical encoder has a very high resolution of 12 nanorad, enabling for instance the determination of the zero-shear viscosity at ultra low shear rates  $< 10^{-6} \text{ s}^{-1}$  or probing delicate samples in oscillation at very small deformations.

## Normal force sensor

The patented\*\* normal force sensor is based on temperature-compensated strain-gauge technology and offers high-resolution normal force measurements within a range of 0.01 to 50 N in both the positive and negative direction. Sensitive tensile strain measurements become possible. Furthermore, it's feasible to perform quick normal force measurements, as well as a timely and accurate compensation of positive and negative normal forces that may result from shrinkage or expansion of the sample.

\* DE 102 47 783 (patent pending), US 6,832,505

\*\* DE 10 2004 050 753 (patent pending), US 7,181,956

## FACTOR 03 EASE OF USE

### Well thought-out design for ease of use and avoiding mistakes

Quick-clamps and quick-connects make it easy to exchange components to adapt the rheometer to new measuring tasks. Easy access to the sample is ensured thanks to the generous dimensioning of the unit.

### Standardized components with quick-connects for plug-and-play operation

All application relevant components of the HAAKE MARS can be exchanged. The individual components, such as temperature modules or measuring geometries, are designed for quick exchange with automatic positioning and alignment. Color-coding and quick connections for cooling media and electronics simplify installation and prevent errors.

### Control and power electronic for error-free measurements

The main control and power electronics are separated from the measuring unit itself, thereby preventing thermal and mechanical interference from heat sources, fans, etc. By removing the secondary control electronics for the lift from the rheometer frame, an opening in the base of the frame can be utilized to access the measuring geometry from below. This is ideal for optical methods that require more space.

### TCP/IP Ethernet interface for fast data acquisition

Using the TCP/IP Ethernet data communication interface allows data points to be acquired and displayed every 2 ms in real time. This is important for measuring samples with fast changing properties, e.g. UV-curing materials.

### Integrated web server for password-protected remote control and maintenance

The rheometer has its own IP address, so the integrated web server can be accessed via the Internet or company intranet for remote control and maintenance or to monitor measurements as they happen.



**Self-centering compact  
temperature modules  
with quick connections**

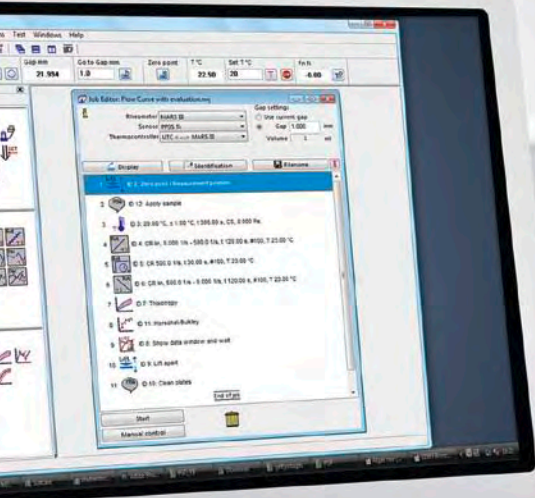

### Benefits of the temperature modules at a glance:

- Plug-and-play modules with new compact design
- Automatic temperature module recognition
- Easy installation in seconds without tools or adjustment
- Standardized connections including quick connects for cooling media and electronics for all modules
- All connections visible from operator position
- No other accessories required, electronics and control valves integrated in HAAKE MARS frame
- Very low thermal mass for fast control response time
- Integrated base so that the dismantled unit can be parked on the lab bench, for example



### Simple, error-free connection of the temperature module electronics

Design-based automatic alignment of the temperature module in the lower HAAKE MARS stand



High-precision production of the lower measuring plate with guide and bayonet ring for simple, plane parallel installation

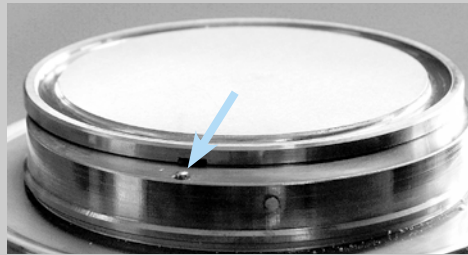

## FACTOR 03 EASE OF USE

# Customizable Thermo Scientific HAAKE RheoWin measuring and evaluation software

### Components

- RheoWin JobManager for fully automated process control (“jobs”) of measuring and analysis routines and report printout or export
- RheoWin DataManager for interactive evaluation of measured data as well as sophisticated tools for creating reports and generating templates for graphs, tables and screen views
- RheoWin UserManager for comprehensive user management regarding user access control and assignment of specific access rights

### Functionality

- Monitor mode for preliminary testing, for displaying selected parameters and for saving manually acquired data
- Convenient creation and customization of measuring routines using predefined measuring and evaluation elements via “drag and drop” techniques
- Fully automated measurement, analysis and documentation within one measuring routine
- Real multitasking – simultaneous measurements using several rheometers and data evaluation
- Freely configurable data export (ASCII, MS-Excel®, XML)
- Save graphs in a wide variety of formats (pdf, jpg, etc.)
- Numerous algorithms for data analysis (e.g. interpolation, regression and automated quality control)
- Availability of saving the raw data and numerical values for data evaluation
- Loop programming with break-up criteria
- Integrated image capture with USB and Firewire camera

### Customization

- User-defined configuration of paths and subdirectories for data filing
- Push-button selection of one out of 12 languages
- Modular generation of a file name and automated saving in a predefined subdirectory
- Data transfer to ERP and laboratory systems (e.g. SAP®, LIMS, etc.)
- Online display of all corrections to improve data quality (Micro Stress Control)
- Snapshot for quick characterization of an unknown sample
- RheoWizard expert help to set up a measuring routine
- Customizable report templates to permit the use of custom logos and text





Data evaluation using Lissajous plots

### Automatic data quality evaluation

Software modules:

- RheoAdaptive Control
- FDA 21 CFR Part 11 compliance (optional)
- Polymer Software (optional)
  - TTS (time-temperature superposition) to create master curves
  - Spectra
  - MWD (molecular weight distribution)
- Interfacial Rheometry (optional)

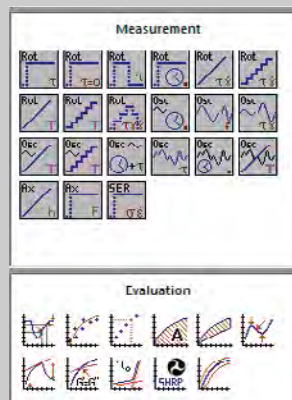

Selection of predefined measurement and analysis elements in HAAKE RheoWin

## FACTOR 04 MODULARITY

### Individual measuring geometries for a wide variety of applications



#### Selection of measuring geometries

Plates, cones, cylinders with helical grooving to prevent sedimentation and vane rotors

**Titanium rotor** with diameter to fit lower plate for optimized gap filling and sample cover (glass or plastic) with integrated solvent trap and inert gas connection

We offer concentric cylinders, plate/plate and plate/cone measuring geometries as well as disposable and custom designs:

- in multiples sizes
- of various materials
- with different surfaces

The standard measuring geometries are made of titanium and designed for use with a solvent trap, such as for measurements on samples that tend to dry out.

For plate and cone measuring geometries, aligned plates are available with the same:

- size
- material
- surface

This ensures ideal measuring conditions, such as optimal sample filling.

A glass sample cover for observing the sample during the measurement is available, as well as an insulated sample cover with integrated solvent trap and inert gas connection to ensure a homogeneous temperature in the sample.

#### Double-cone geometry for measurements on low viscosity samples

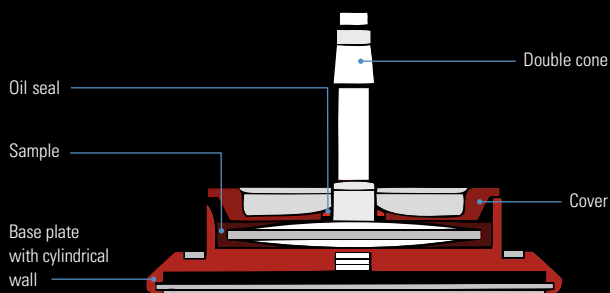

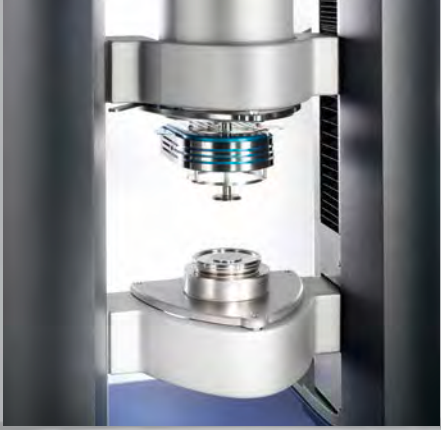

Electric temperature module for plate/cone measuring geometries



Rear view of the active upper temperature control unit

### Temperature modules for fast, precise temperature control within a broad temperature range

There is a large selection of temperature modules available for the HAAKE MARS III, covering a temperature range from -150 °C to 600 °C. Depending on the application, electric, liquid, controlled temperature modules or Peltier are available. In addition a controlled temperature test chamber is offered.

**Peltier** – for fast temperature changes within the mid temperature range from -60 to 200 °C

**Liquid** – for very precise, constant temperature control; the most reasonably priced temperature control method when using an existing thermostat.

**Electric** – for measurements within a broad temperature range

- plate and cone measuring geometries can be combined with a measuring chamber up to 400 °C using the active upper temperature module and a ring of tempered glass, also for visual inspection under inert gas
- for very fast temperature changes using cylinder measuring geometries or application-focused measuring cells such as high pressure measuring cells

**Controlled Test Chamber (CTC)** – Patented\* combination of convection and radiation heat transfer for very fast temperature changes and homogeneous temperature distribution from 30 to 600 °C, can be extended to -150 °C with the premium low temperature option.

**Universal active and passive upper temperature modules** – can be combined individually with the lower temperature module. The adaptation is done in seconds with adjusting mechanism to fit the measuring head, with trim position for optimal filling, nitrogen connection for inert gas atmosphere and integrated solvent trap.

\* DE 102004050751 (registration), US 11/244,221 (registration)

FACTOR 05  
APPLICATION SOLUTIONS



## Open platform for specific expansions

Thanks to its spacious and modular design, the Thermo Scientific HAAKE MARS rheometer can be easily and quickly adapted to new requirements. A variety of specialized and application-oriented measuring cells are available, e.g. for food, construction materials or UV-curing materials.

# FOR 05 APPLICATIONS



Petrochemicals

Pharmaceuticals and cosmetics

Paints and coatings

Polymers

Custom measurement setups can be realized on request: The measuring head can be installed in the bottom holder if desired for optimal positioning in a beam path to enable the use of two measuring heads.

We are glad to consult you on further applications and can offer a broad accessory portfolio for these, too.

## FACTOR 05 APPLICATION SOLUTIONS

### Polymers

Our equipment covers the entire life cycle of a polymer – from its development to the pilot. Small batches can be compounded using the scale-up method or small quantities of specialized polymers or composites can be processed up to (online) quality control in production.

#### Compounding and test specimen production

We provide comprehensive workflow coverage with the Thermo Scientific HAAKE MiniLab micro-compounder together with the Thermo Scientific HAAKE MiniJet mini-injection molding machine. The HAAKE MiniLab combines compounding and viscosity tests for small sample volumes up to 5 g or 7 cm<sup>3</sup>. This unit is based on the

proven conical twin-screw technology, with co- or counter rotating screws, and can operate as a separate unit with data export or as a fully software-controlled system. Together with the HAAKE MiniJet, different specimens can easily be produced from the compounded material.

#### Rheological measurements

With the Thermo Scientific HAAKE MARS rheometer, the visco-elastic properties of polymer melts or solids can be measured as a function of shear, elongation, time, frequency, temperature, etc. – not only under shear but also under elongation strain.



### Polymer Workflow Solution

#### HAAKE Minilab

Very small batch compounding for research and development.

#### Solid clamp

Clamps for solid samples for measurements according to DIN/ISO 6721-1. These clamps are self-centering and self-adjusting to automatically compensate for physical changes of the sample (e.g. expansion or contraction due to temperature changes).

#### Mini-injection molding machine

With various molds for the production of specimens for rheological tests: disk-shaped, in various diameters, for plate/plate measuring geometries or rectangular for the solid clamp.



HAAKE MARS with controlled temperature chamber and clamps for measuring solids, SER tool for extensional rheological measurements and RheoScope unit

### Selection of polymer-specific accessories:

- ✓ Micro-compounder
- ✓ Injection molding machine for the production of test specimens
- ✓ Disposable pellet filling aid for optimal gap filling
- ✓ CTC controlled temperature test chamber for measurements in the range (-150) 30 to 600°C
- ✓ Solid clamp for DMA tests on rod-shaped specimens
- ✓ SER tool from Xpansion Instruments for extensional rheological measurements
- ✓ Interchangeable plate and cone measuring geometries in various sizes and materials
- ✓ Measuring cell for UV-curing processes or for thermal assisted UV-curing
- ✓ RheoScope module for the measurement of the melting behavior of polymers
- ✓ HAAKE RheoWin Software-Module TTS, Spectra and MWD

## FACTOR 05 APPLICATION SOLUTIONS

### Petrochemicals

Over 30 billion barrels of crude oil are conveyed and processed annually. Measurements of the viscosity of crude oils of varying compositions at different temperatures and pressures are used to optimize the flow behavior of the crude oil at various depths, while simulating and optimizing extraction and transport. The calculated use of drilling and boring fluids can increase oil field outputs.

Here too we have the entire process covered, from extraction to processing.

#### Extraction

For temperature- and pressure-dependent measurements, there is a comprehensive range of measuring cells in various materials (titanium, Hastelloy®, etc.) available, suitable for up to 400 bar and 300 °C. Cylindrical geometries or vane rotors are available as

measuring geometries to simulate the starting behavior of pipelines. Isobaric measurements can be done using an automated pressure controller while performing temperature ramps.

#### Transport

Simultaneous measurements of rheological properties with the help of microscopic observation of structure formation to study the crystal growth in crude oils ("waxing"), which must be avoided in order to optimize pipeline transport.

#### Processing

We offer several application-based measuring cells for petroleum processing and refining, such as for the rheological testing of bitumen or for tribological and rheological testing of oils and lubricants.

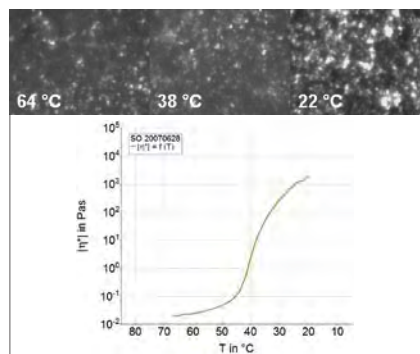

Early detection of crystal deposits on the inside of pipelines, known as waxing, is possible by means of rheo-optical measurements (cooling ramp in the oscillation test) so that countermeasures can be taken.

Measuring cells for determining the tribological behavior of material combinations with or without lubricants.



HAAKE MARS with high pressure measuring cell

**Selection of specific accessories for the petrochemical industry:**

- ☑ Pressure measuring cells: up to 300 °C and 400 bar, titanium and Hastelloy®, with cylindrical and vane rotors
- ☑ Pump for pressurization and automatic regulator for isobaric measurements
- ☑ RheoScope module for studying the waxing behavior of crude oil
- ☑ SHRP measuring cells for the rheological characterization of bitumen
- ☑ Tribology measuring cell for abrasion tests with greases and lubricants

## FACTOR 05 APPLICATION SOLUTIONS

### Pharmaceuticals and cosmetics

Nasal sprays, creams, foams, tablet coatings, shelf life, sprays or active ingredient dosing – no matter what the product or application – rheological tests are essential for the development, optimization or production of suspensions and emulsions in order to reduce product development times and optimize production processes.

While simple viscosity measurements are often sufficient for evaluating raw materials, extensive rheological testing is necessary in order to predict and effectively adjust shelf life, sensitivity or processability. The HAAKE MARS has an extensive range of accessories for pharmaceutical and cosmetic applications.



Selection of falling ball and rotational viscometers for fast, reliable viscosity measurement for raw material evaluation or batch testing



Universal holder for measurements in original containers (e.g., cream jars or cosmetic pots)



Submersion flow cell with fluid for testing interactions between creams and salves with human skin or bandage adhesion when subjected to skin secretions



HAAKE MARS with Du Noüy ring for rheological measurements of interfaces, microtiter plate with liquid temperature control for serial measurements or measurements with small sample volumes

### Selection of accessories for pharmaceutical products and cosmetics:

- ✓ High-performance Peltier temperature control unit for temperature cycle tests for stability testing
- ✓ RheoScope Module for stability testing of multi-phase systems and foams, plus SPIP software determining particle sizes and distribution
- ✓ Du Noüy ring for interfacial rheology
- ✓ Variable holder for measurements in original containers
- ✓ Holder for microtiter plates for serial measurements of samples that are only available in small volumes
- ✓ Submersion flow cell surrounded by fluid
- ✓ Custom solutions for processing pharmaceutical products (hot melt extrusion, continuous granulation)
- ✓ "21 CFR Part 11" module for the HAAKE RheoWin software to meet FDA requirements

## FACTOR 05 APPLICATION SOLUTIONS

### Paints, inks and coatings

The requirements and demands placed on paints, inks and coatings are constantly increasing. And in the process, eco-friendly technologies and products are growing in importance: water as a diluting agent, solvent-free powder coatings and UV irradiation as a fast, energy-saving cross-linking method.

The flow behavior of these products is highly complex, but can be controlled when the relevant parameters are known. Suitable rheology additives can be selected depending on the desired

formulation, whether they contain solvents or are water-based. For instance, existing coating systems can be reformulated to be in compliance with the law without significant changes to the flow characteristics, or customized photo-initiators that are mixed into the coating as an additive are developed to enable UV cross-linking. The result is a shorter drying times and therefore lower process costs. Our equipment supports you in every phase of your multi-layered process.



Thermo Scientific HAAKE CaBER 1, the only commercially available rheometer to measure the extensional properties of fluids, e.g. to optimize a curtain coating or for filling processes.

UV measuring cells as an integrated solution for the controlled test chamber (CTC) to enable the measurement of UV-induced thermal curing.



HAAKE MARS with controlled test chamber (CTC) and measuring cell for UV curing

### Selection of application-specific accessories for paints, inks and coatings:

- ✓ Sample covers, including solvent traps to prevent drying out
- ✓ Double cone to measure low-viscosity paints without any edge effect
- ✓ Plate/ring measuring geometry for measuring powder coatings
- ✓ Disposable plate/plate measuring geometry to eliminate time-consuming cleaning
- ✓ Measurements with very high shear rates using special cylinders with small measuring gaps (up to 25  $\mu\text{m}$ ) or cones with small cone angles
- ✓ UV measuring cells for standard and custom applications such as UV-assisted thermal curing
- ✓ Rheometer for measuring extensional properties, such as during spraying or coating
- ✓ Dynamic contact angle analysis to measure the wetting behavior of surfaces

# FACTOR 05 APPLICATION SOLUTIONS

## Custom measuring equipment

Rheology is as diverse as our customers' applications and is subject to constant change. Close cooperation with our customers and our employees' high level of expertise enable the constant development of our rheometers and their accessories:

### Measuring cell for large particles

There is a patented\* special measuring cell with a flexible profile for measuring samples with particularly large particles (such as building materials) available. Thanks to the flexible number and depth of the profile lamellas, the measuring cell can be easily and quickly adapted to new materials. The design prevents slippage layer formation and the measuring cell captures a large volume in order to ensure a homogeneous sample.

\* DE 10 2006 022 316, US 11/797,922 (patent pending)



Measuring cell for large particles, such as building materials

### Normal force functionality and relevant measurements

The HAAKE MARS, which comes equipped with a normal force sensor, not only measures normal force differences in shear experiments but also compensates for changes in sample volume. An axial force can be applied to the sample for abrasion tests and texture analysis so that the HAAKE MARS can be used as a very precise "tack" instrument to determine the tackiness of a sample.

### Measuring units for bending and breakage tests

This measuring instrument consists of a bottom sample holder with variable cutting to position the material to be measured and a top measuring geometry for mechanical load.

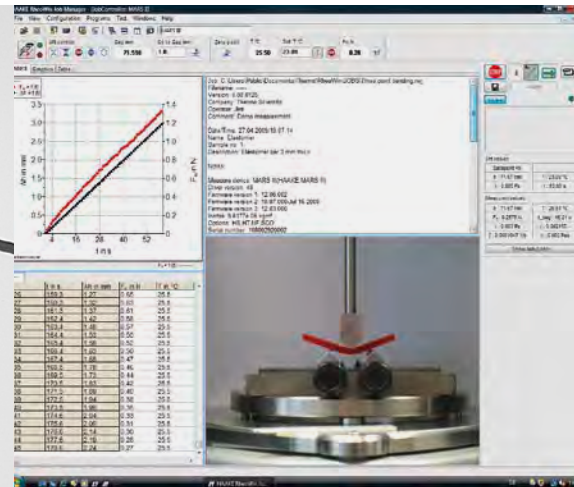

Bending test on polymer sample, Thermo Scientific HAAKE RheoWin software to record measurements and images

## Combined measuring methods

Rheology is a “macroscopic” method that provides information on the behavior of a sample under specified conditions. The mechanical properties of a material depend on its structure at the microscopic level. In order to be able to determine the reasons for the rheological properties, rheological measurements must be combined with tests on the microscopic level, using FTIR or microscopy, for example.

Benefits of combined methods:

- Same sample preparation
- Same measuring conditions
- Shorter test times
- Perfect correlation of results

### RheoScope Module

The RheoScope module was specially developed for the HAAKE MARS and brings microscopy together with state of the art rheometer technology:

- Compact modular unit
- Full rheometer functionality, including

normal force measurement, while simultaneously recording microscopic characteristics

- Camera and lenses are software-controlled
- Simultaneous rheological and optical measurements
- Visualization of data and images in the same software package
- Analysis of structural changes under shear
- Image analysis software to determine particle sizes, particle size distributions and structural analysis.

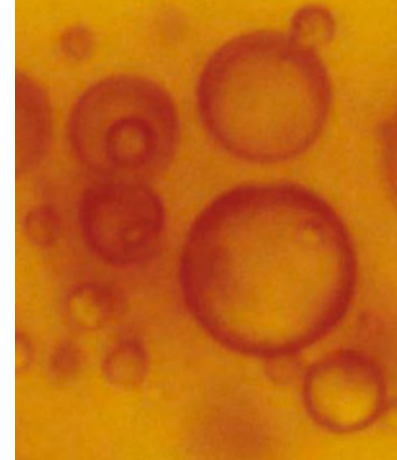

### Specifications of the RheoScope module

#### Lenses

Microscope	Focus and radial positioning by software-controlled servo motors
Lens <sup>1</sup>	5x, 10x, 20x and 50x
Light source <sup>1</sup>	150 W, 12 V, wave length range: 380-750 nm
Resolution	1 µm (20x lenses)
Field depth	5 µm (20x lenses)
Contrast improvement	Polarizer adjustable by software-controlled servo motor
Camera	Black-and-white 'progressive' scan CCD camera, with 1024 x 768 pixels, C connector and IEEE 1394 (Firewire) interface

#### Data acquisition and storage

Data acquisition	Up to 30 images per second <sup>2</sup> in HAAKE RheoWin 4 software
Storage	As image (3 standard image formats: TIFF, BMP, LWF) or Video sequences (configurable data compression)

#### Temperature range

Standard version	-5 <sup>3</sup> – 120 °C (liquid temperature control unit)
High temperature option	-5 – 300 °C (electrical temperature control unit)

#### Measuring geometries

Using a plate/plate and plate/cone measuring geometry with polished surface is recommended.

<sup>1</sup> This component uses standard interfaces, individual components can be adapted

<sup>2</sup> Depending on the performance parameters of the computers used

<sup>3</sup> Depending on thermostats

## FACTOR 05 APPLICATION SOLUTIONS



## Custom services

We are committed to customer support, including specific service products, short response times, and customer-specific solutions. To quickly and flexibly meet our customers' requirements, we offer a comprehensive range of services.

### Application laboratories

Our fully equipped laboratories reflect our application expertise and commitment to innovation. Our laboratories are in constant demand for testing customer samples and developing and optimizing pioneering applications.

### Application support

We provide comprehensive product and application solutions and our application specialist team is on hand to answer your questions.

### Seminars and training courses

Customers are offered a comprehensive training program and selected courses in our international training center in Karlsruhe, Germany. Basic and advanced rheology seminars and training on special applications are held worldwide. In-house seminars are also offered to our customers. For more information visit [www.thermo.com/mc\\_seminar](http://www.thermo.com/mc_seminar).

### Services to meet individual requirements

We offer a wide range of professional services to a variety of industries to help our customers improve their productivity and decrease costs. Individual solutions to support our customers and maintain their instruments are a standard service. Additional service packages, warranty extensions or premium service packages, which can be bundled, allow our customers to plan and budget for maintenance and service support. All services are provided by skilled and certified service engineers.

### Selected product information:

- P17 new measuring cell for UV-assisted thermal curing
- P19 SER measuring system for extensional rheological testing with the HAAKE MARS
- P23 measuring cell for tribological tests using a HAAKE rheometer
- P26 Du Noüy ring for interfacial rheology
- P27 rheological tests on small sample volumes: liquid temperature controlled holder for microtiter plate



- Looking for something else? Contact us!

# HAAKE MARS III Specifications

## Technical data

Min. torque rotation CS	0.01 $\mu$ Nm
Min. torque rotation CR	0.01 $\mu$ Nm
Min. torque oscillation CS	0.003 $\mu$ Nm
Min. torque oscillation CD	0.003 $\mu$ Nm
Max. torque	200 mNm
Torque resolution	0.1 nNm
Motor inertia	10 $\mu$ Nms
Motor type	Drag cup
Bearing type	Air bearing: 2x radial, 1x axial
Angular resolution	12 nrad
Step in strain	30 ms
Min. rotational speed CS	10 <sup>-7</sup> rpm
Min. rotational speed CR	10 <sup>-8</sup> rpm
Max. rotational speed	1500 (4500 <sup>b</sup> ) rpm
Step in velocity	10 ms
Min. oscillation frequency	10 <sup>-6</sup> Hz
Max. oscillation frequency	100 Hz
Min. Normal force	0.01 N
Max. Normal force	50 N
Normal force resolution	0.001 N
Max. lift travel	240 mm
Gap resolution	0.5 $\mu$ m
Min. lift speed	0.02 $\mu$ m/s
Max. lift speed	20 mm/s
Min. temperature	-150 °C
Max. temperature	600 °C
Dimensions (W x D x H)	600x600x890 mm
Weight	59 kg

## Features

CD-OSC <sup>a</sup>	Yes
OSC raw data / Lissajous	Yes
Multiwave	Yes
Gap control: Force / speed / path for squeeze- and tack test / texture analysis	Yes/Yes/Yes
Camera for image capturing	Standard (USB, Firewire)
Titanium measuring geometries with low inertia	Standard
Replaceable lower plates of various diameters / surfaces / materials	Yes/Yes/Yes
Quick couplings for temperature module recognition	Yes
Temperature module recognition	Yes

## Temperature modules

Peltier controlled plate	-60 °C - 200 °C
Electrically controlled hood	-40 °C - 400 °C <sup>(e)</sup>
Liquid controlled plate	-40 °C - 200 °C
Electrically controlled plate	-40 °C - 400 °C
Liquid controlled cylinder	-40 °C - 180 °C
Electrically controlled cylinder	Max. 300 °C*
Controlled test chamber	-150 °C - 600 °C

<sup>a</sup> True deformation control      <sup>b</sup> Option for high shear rates  
<sup>c</sup> Depending on temperature module      <sup>(e)</sup> Electrical  
 \* When using suitable measuring geometries

Thermo Scientific Service à la Carte is customer-oriented and covers all types of services. We also offer custom-designed service programs that support IQ/OQ requirements for example. Our service and applications specialists are available around the world to protect your investments. For details visit [www.thermo.com/mc\\_service](http://www.thermo.com/mc_service).

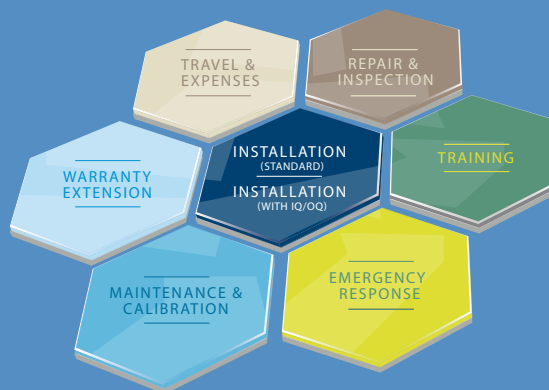

## About Thermo Fisher Scientific

Thermo Fisher Scientific Inc. (NYSE: TMO) is the world leader in serving science, enabling our customers to make the world healthier, cleaner and safer. With annual revenues of \$10.5 billion, we have approximately 34,000 employees and serve over 350,000 customers within pharmaceutical and biotech companies, hospitals and clinical diagnostic labs, universities, research institutions and government agencies, as well as environmental and industrial process control settings. Serving customers through two premier brands, Thermo Scientific and Fisher Scientific, we help solve analytical challenges from routine testing to complex research and discovery. The Thermo Scientific brand represents a complete range of high-end analytical instruments as well as laboratory equipment, software, services, consumables and reagents to enable integrated laboratory workflow solutions. Fisher Scientific provides a complete portfolio of laboratory equipment, chemicals, supplies and services used in healthcare, scientific research, safety and education. Together, we offer the most convenient purchasing options to customers and continuously advance our technologies to accelerate the pace of scientific discovery, enhance value for customers and fuel growth for shareholders and employees alike. Visit [www.thermofisher.com](http://www.thermofisher.com).

As one of the pioneers in rheology, Thermo Fisher Scientific successfully supports a wide range of industries with its comprehensive Thermo Scientific Material Characterization solutions. These products analyze and measure viscosity, elasticity, processability and temperature-related mechanical changes in plastics, food, cosmetics, pharmaceuticals and inks, coatings, or petrochemical products. For more information, please visit [www.thermo.com/mc](http://www.thermo.com/mc).

© 2009/06 Thermo Fisher Scientific Inc. - All rights reserved. 623-2107. ® Hastelloy is a registered trademark of Haynes International, Ltd. MS-Excel is a trademark of the Microsoft group of companies. SAP is a registered trademark of SAP AG. All other trademarks are the property of Thermo Fisher Scientific Inc. and its subsidiaries. This document is for informational purposes only. Specifications, terms and pricing are subject to change. Not all products are available in every country. Please consult your local sales representative for details.

### Process Instruments

#### Benelux

Tel. +31 (0) 76 579 55 55  
[info.mc.nl@thermofisher.com](mailto:info.mc.nl@thermofisher.com)

#### China

Tel. +86 (21) 68 65 45 88  
[info.mc.china@thermofisher.com](mailto:info.mc.china@thermofisher.com)

#### France

Tel. +33 (0) 1 60 92 48 00  
[info.mc.fr@thermofisher.com](mailto:info.mc.fr@thermofisher.com)

#### India

Tel. +91 (20) 6626 7000  
[info.mc.in@thermofisher.com](mailto:info.mc.in@thermofisher.com)

#### United Kingdom

Tel. +44 (0) 1606 548 100  
[info.mc.uk@thermofisher.com](mailto:info.mc.uk@thermofisher.com)

#### USA

Tel. 603 436 9444  
[info.mc.us@thermofisher.com](mailto:info.mc.us@thermofisher.com)

#### International/Germany

Dieselstr. 4  
76227 Karlsruhe  
Tel. +49 (0) 721 4 09 44 44  
[info.mc.de@thermofisher.com](mailto:info.mc.de@thermofisher.com)

[www.thermo.com/mc](http://www.thermo.com/mc)

**Thermo**  
SCIENTIFIC